

Athena 2 EN 2500

LIBRA

Piantana ad annegare

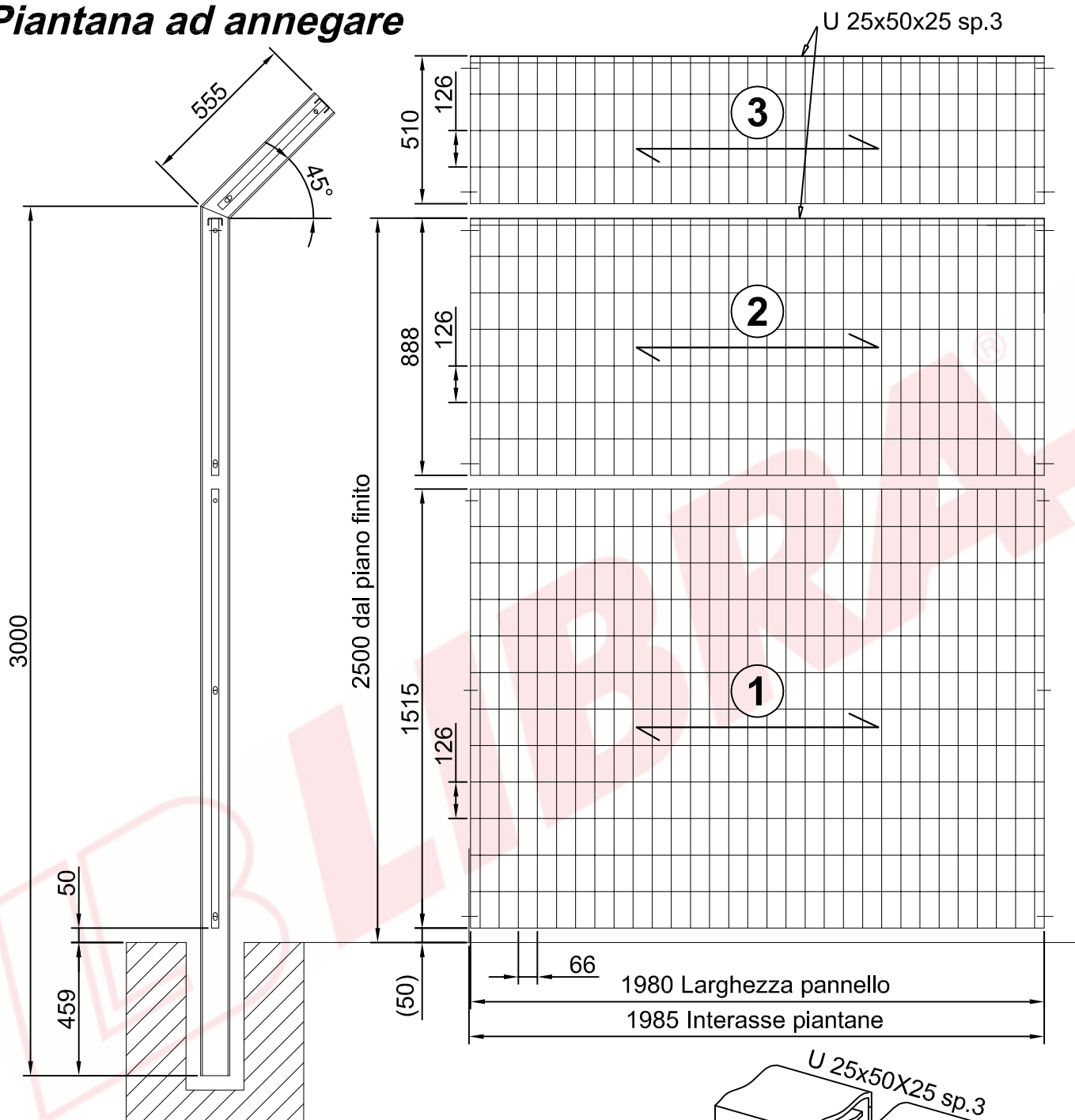

Altezza recinzione mm	Peso pannello 1 kg/cad	Peso pannello 2 kg/cad	Peso pannello 3 kg/cad
2500 + 510	22,1	17,9	12,6

Tipo piantana	Altezza piantana mm	Peso piantana kg/cad
IPE 100	3000 + 555	30,5

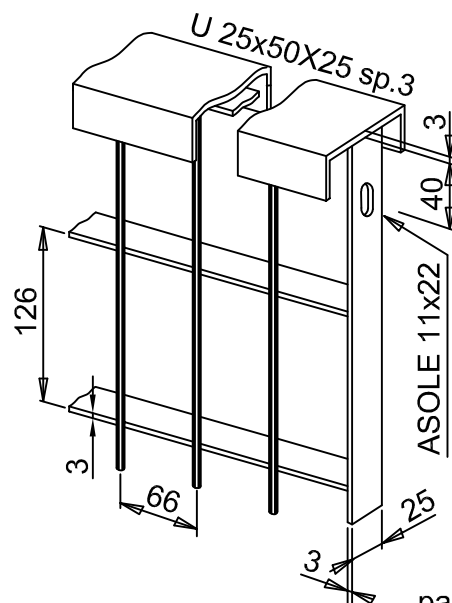

Materiale: S235JR EN 10025

Trattamento superficiale: Zincatura a caldo UNI EN ISO 1461

Athena 2 EN 2500

LIBRA

Piantana con piastra di base

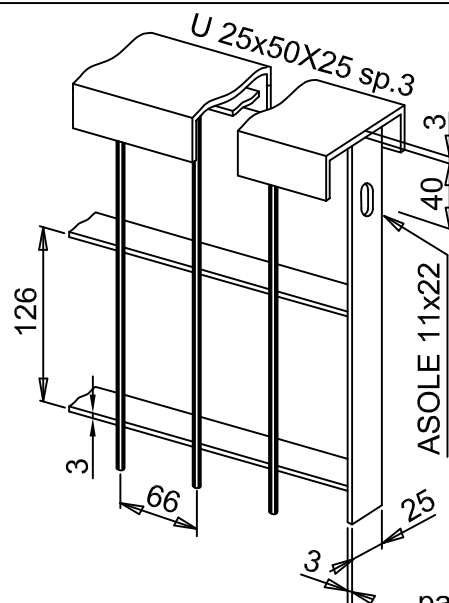
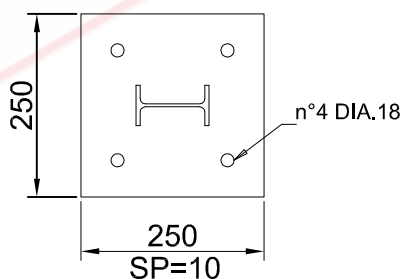
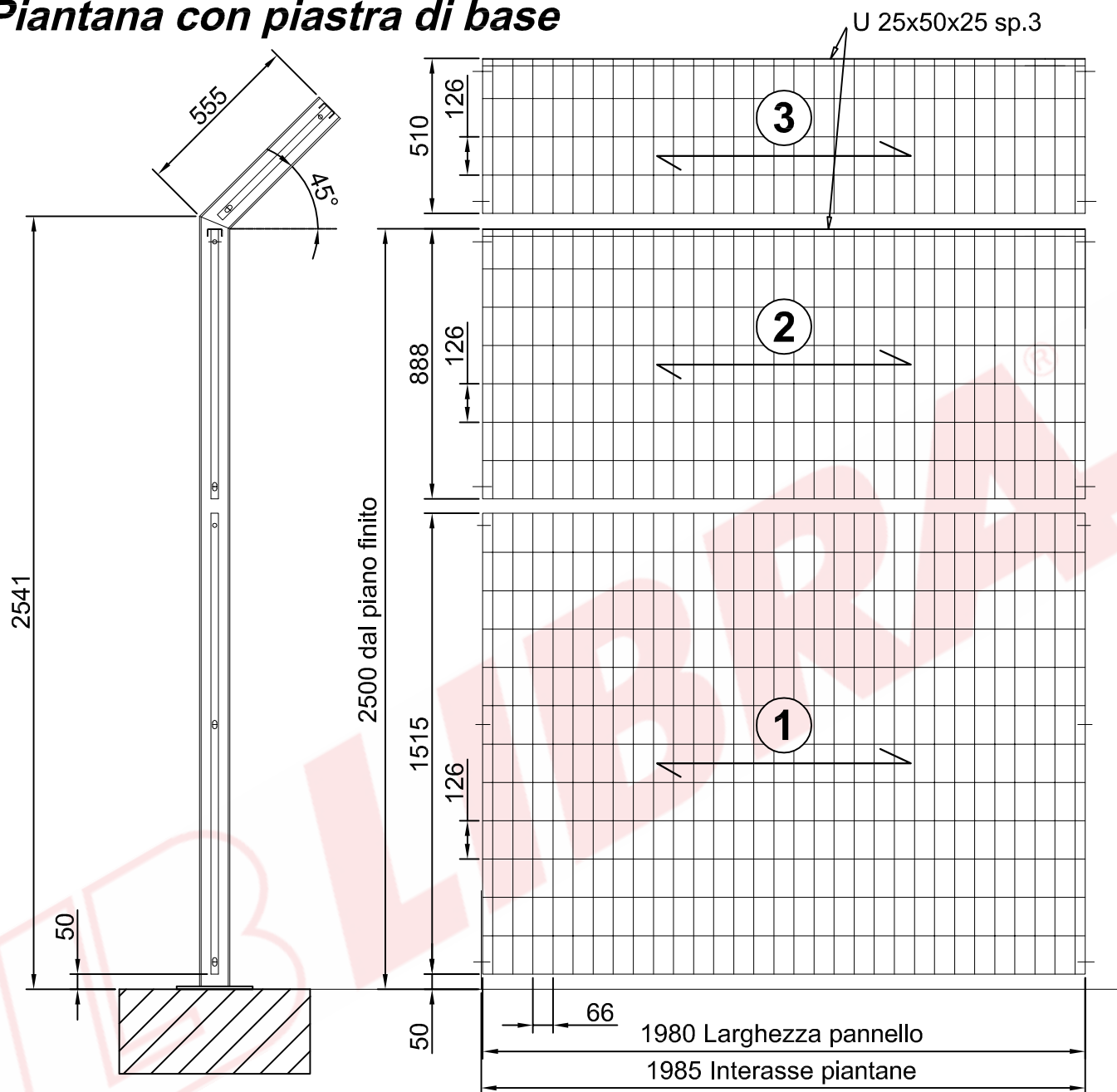

Altezza recinzione mm	Peso pannello 1 kg/cad	Peso pannello 2 kg/cad	Peso pannello 3 kg/cad
2500 + 510	22,1	17,9	12,6

Tipo piantana	Altezza piantana mm	Peso piantana kg/cad
IPE 100	2541 + 555	31,8

Materiale: S235JR EN 10025

Trattamento superficiale: Zincatura a caldo UNI EN ISO 1461