

Hauteur panneau mm	Section poteau mm	Longueur poteau mm	Poids module kg/m ²
930	plat 60x7	1200	9,8
1195	plat 60x7	1465	9,3
1320	plat 60x7	1650	9,3
1460	plat 60x7	1790	9,1
1720	plat 60x7	2085	8,9
1985	plat 60x7	2350	8,7

Poteau sur platine plate

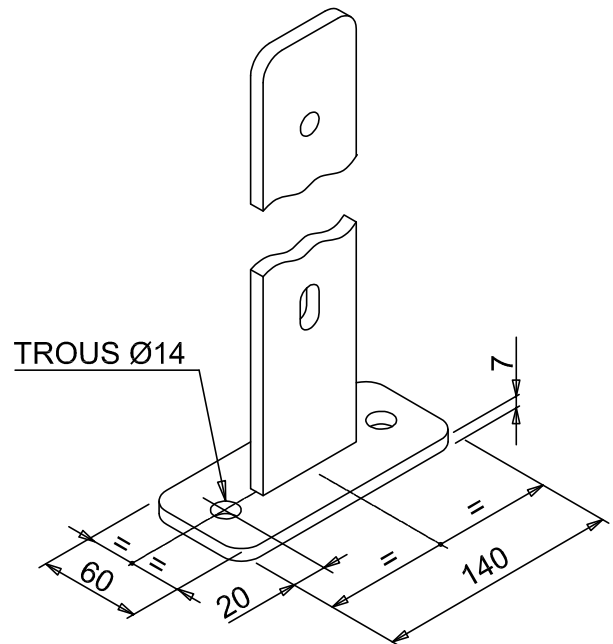

Hauteur panneau mm	Section poteau mm	Longueur poteau mm	Poids module kg/m ²
930	plat 60x7	990	9,7
1195	plat 60x7	1255	9,2
1320	plat 60x7	1380	9,1
1460	plat 60x7	1520	9,0
1720	plat 60x7	1780	8,7
1985	plat 60x7	2045	8,6

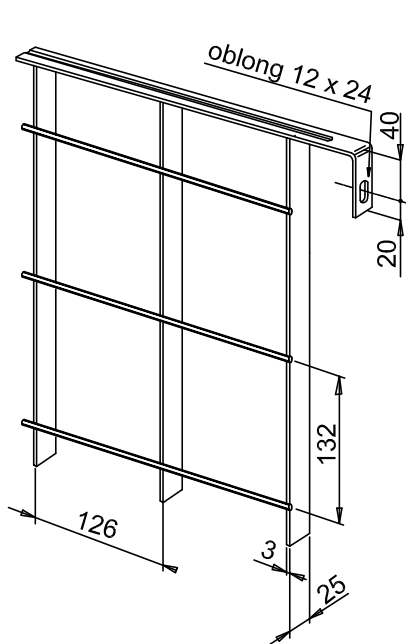
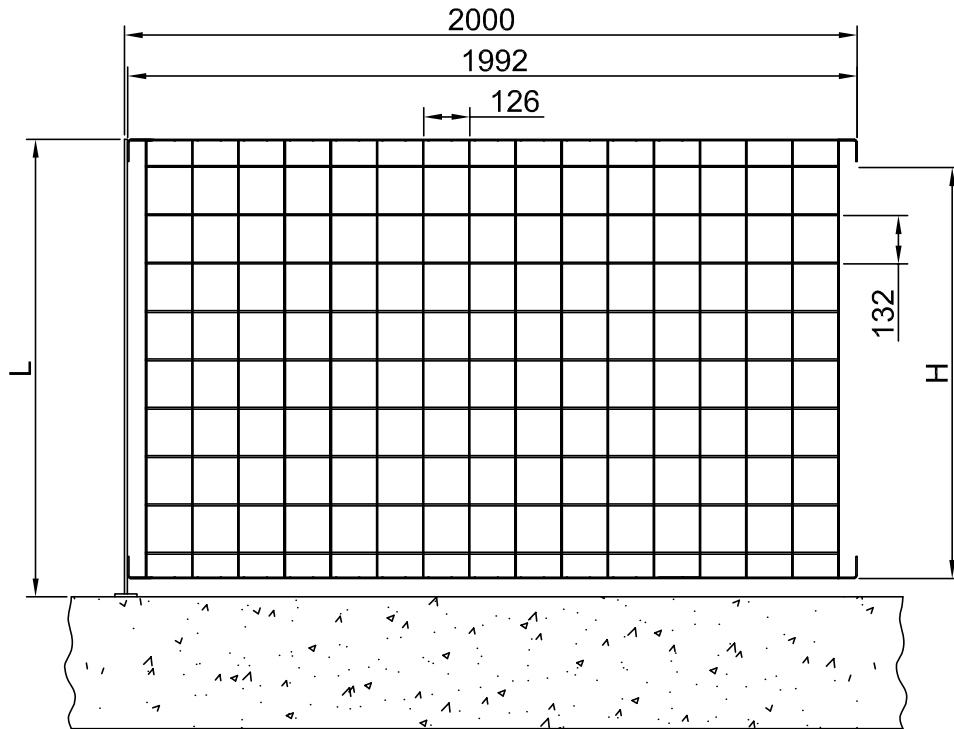
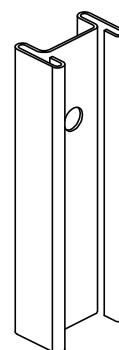
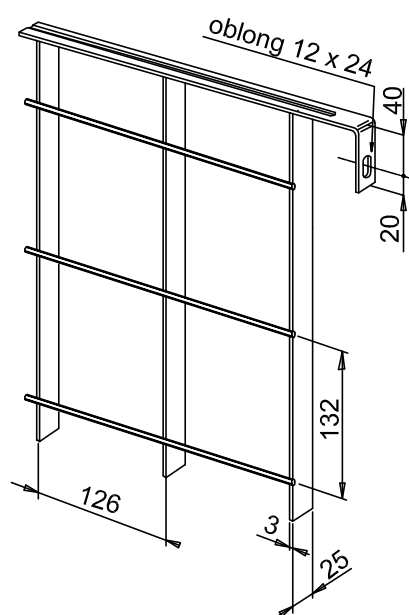
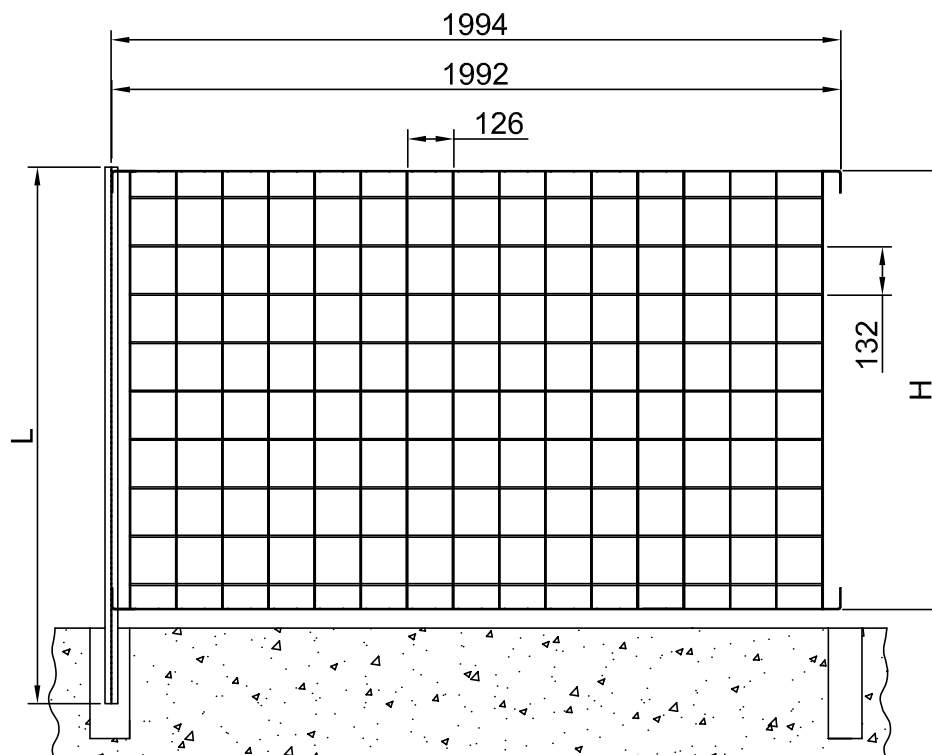

Hauteur panneau mm	Section poteau	Longueur poteau mm	Poids module kg/m ²
930	PROFILE'	1200	9,2
1195	PROFILE'	1465	8,7
1320	PROFILE'	1650	8,7
1460	PROFILE'	1790	8,5
1720	PROFILE'	2085	8,3
1985	PROFILE'	2350	8,2

Poteau *STYLE* sur platine plate

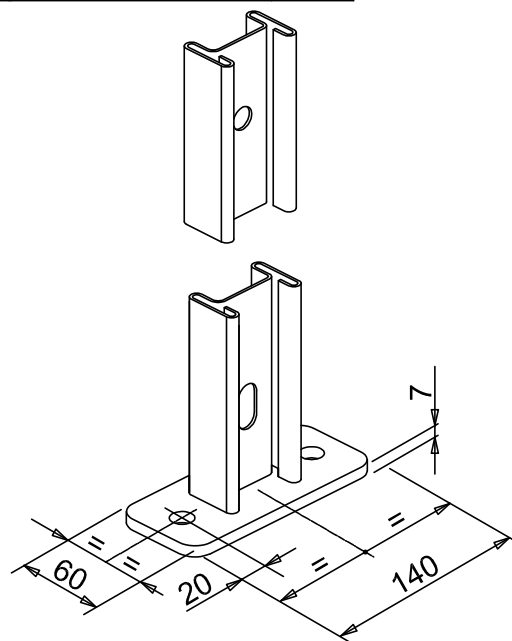
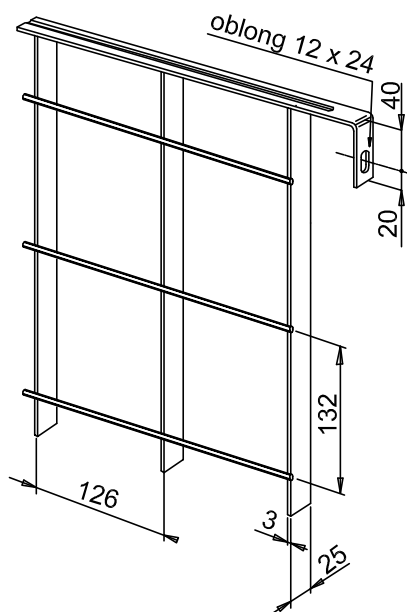
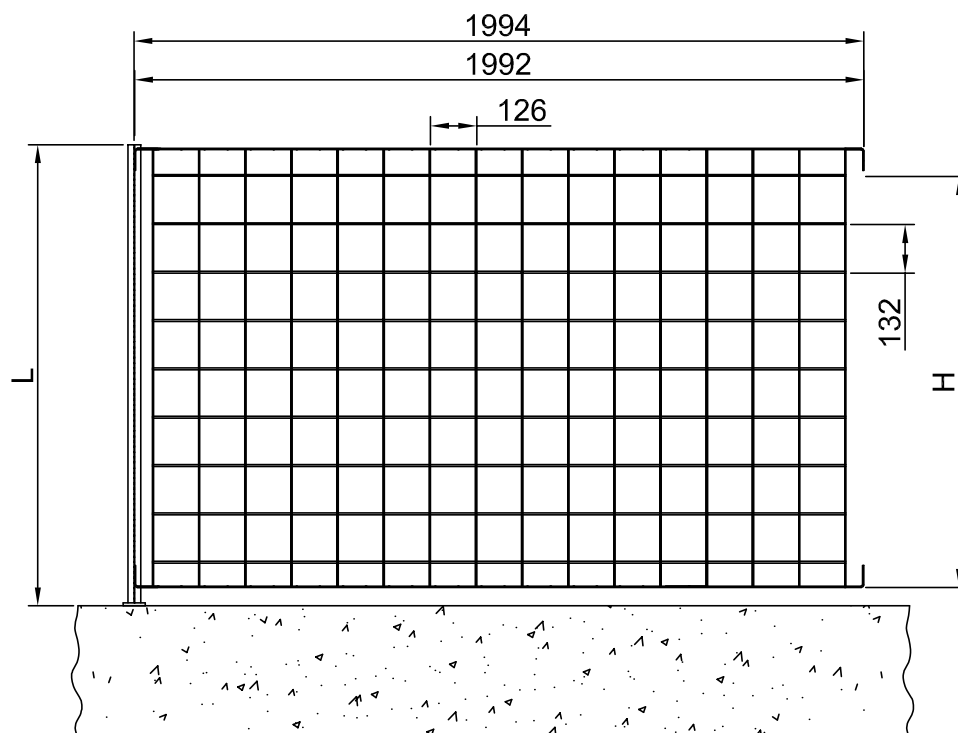

Hauteur panneau mm	Section poteau	Longueur poteau mm	Poids module kg/m ²
930	PROFILE'	990	9,2
1195	PROFILE'	1255	8,7
1320	PROFILE'	1380	8,6
1460	PROFILE'	1520	8,5
1720	PROFILE'	1780	8,2
1985	PROFILE'	2045	8,1