

# Athena 2 EN 2200

**LIBRA**

## Piantana ad annegare

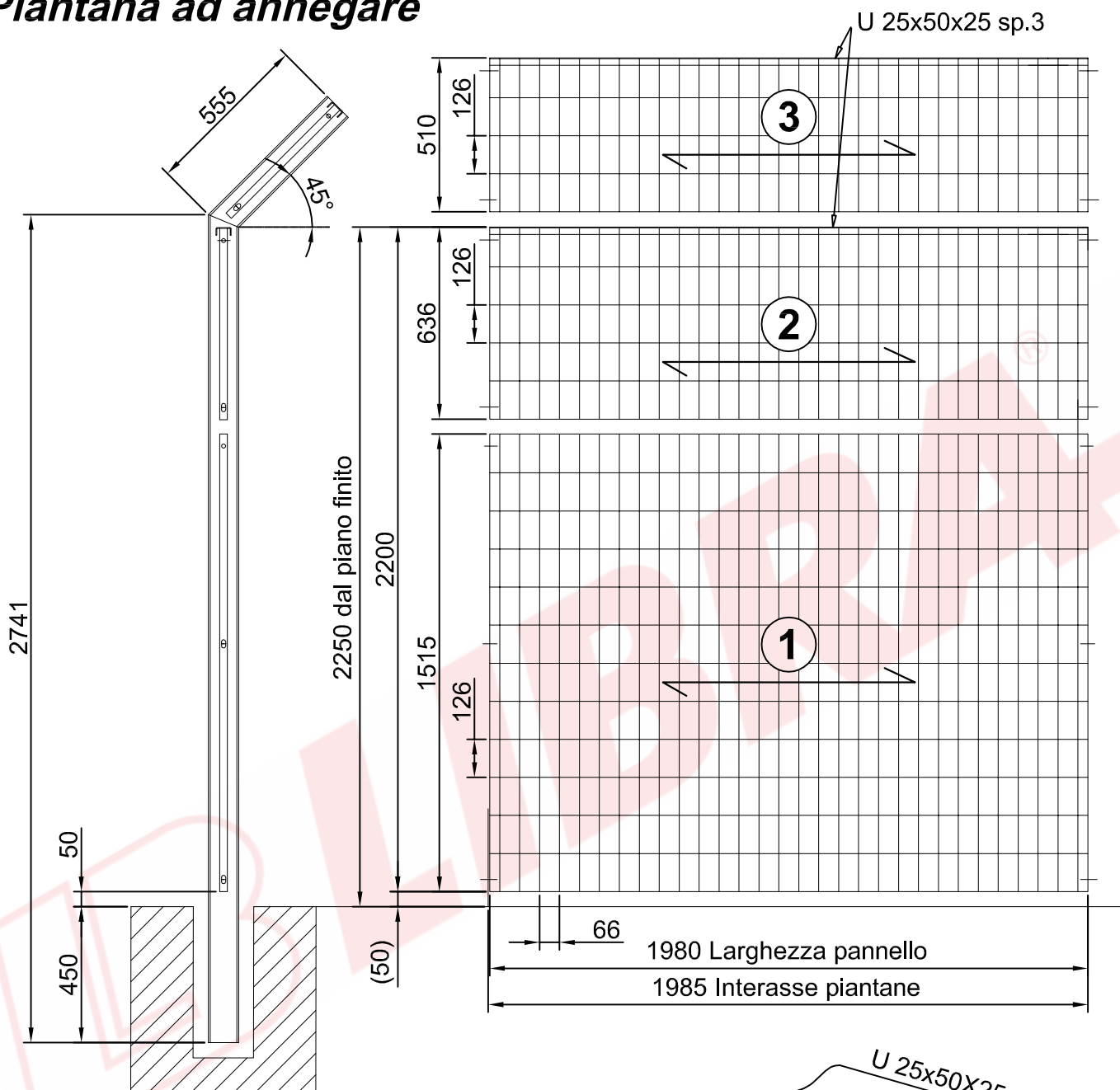

Altezza recinzione mm	Peso pannello 1 kg/cad	Peso pannello 2 kg/cad	Peso pannello 3 kg/cad
2250 + 510	22,1	14,4	12,6

Tipo piantana	Altezza piantana mm	Peso piantana kg/cad
IPE 100	2741 + 555	28,3

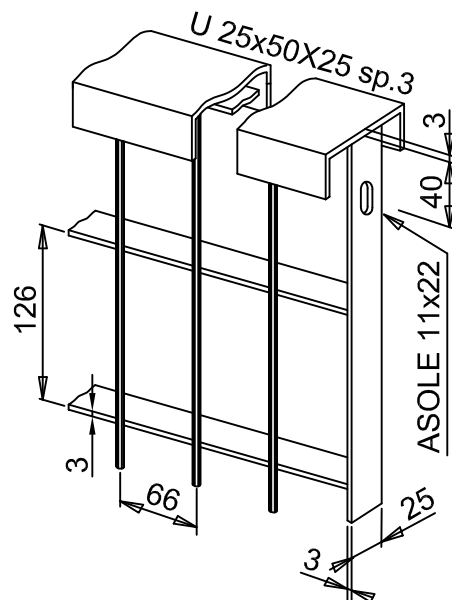

Materiale: S235JR EN 10025

Trattamento superficiale: Zincatura a caldo UNI EN ISO 1461

# Athena 2 EN 2200

**LIBRA**

## Piantana con piastra di base

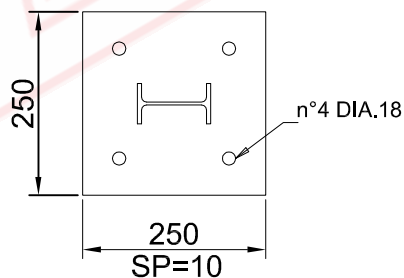
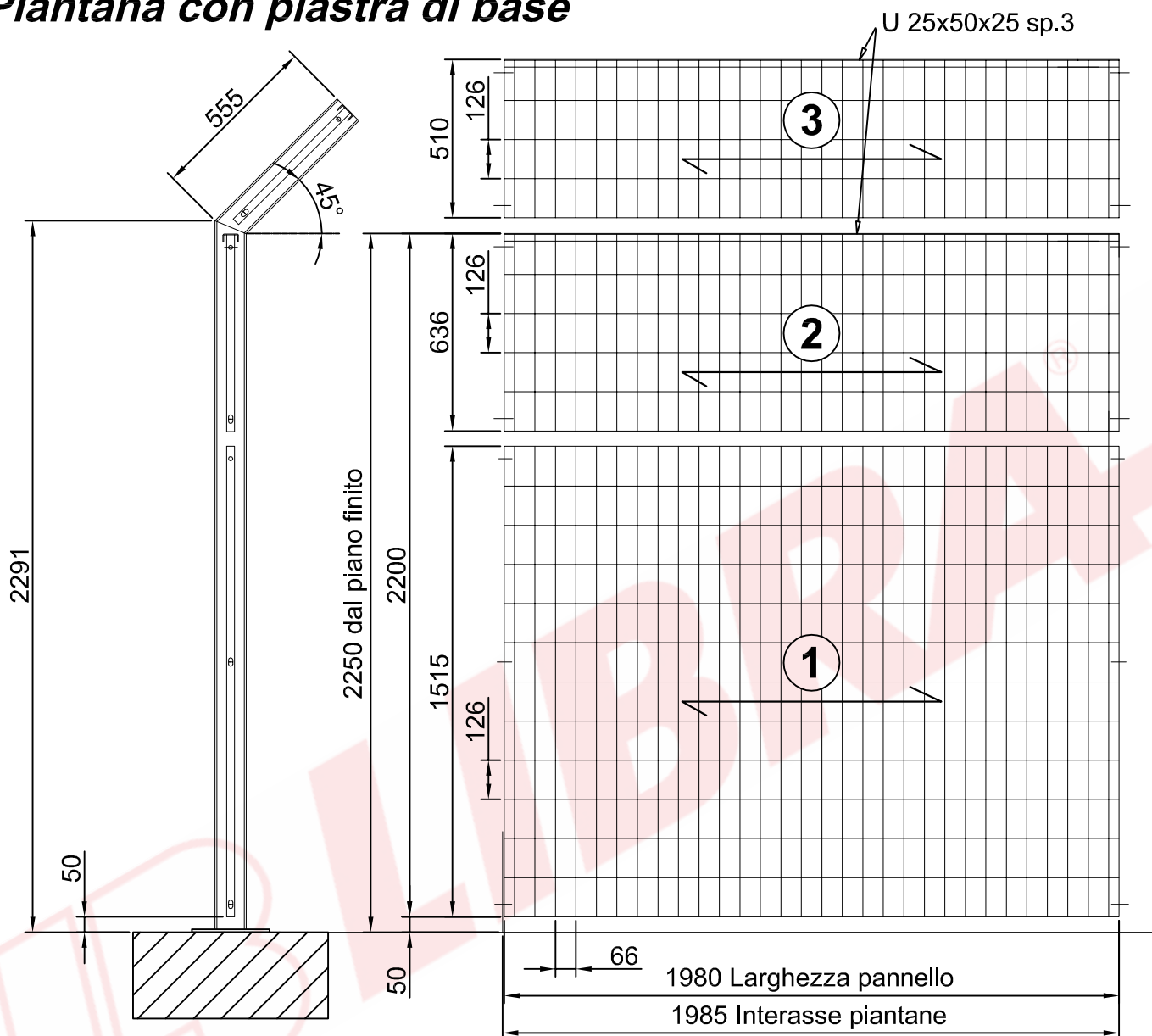

Altezza recinzione mm	Peso pannello 1 kg/cad	Peso pannello 2 kg/cad	Peso pannello 3 kg/cad
2250 + 510	22,1	14,4	12,6

Tipo piantana	Altezza piantana mm	Peso piantana kg/cad
IPE 100	2291 + 555	29,5

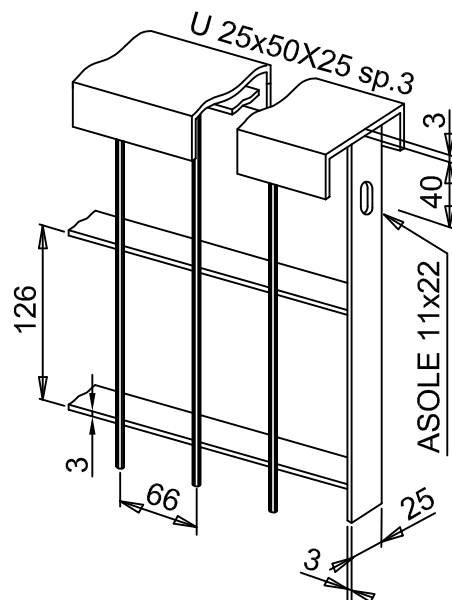

Materiale: S235JR EN 10025

Trattamento superficiale: Zincatura a caldo UNI EN ISO 1461