

Linear 30° PASSO 100

LIBRA

Piantana in piatto ad annegare

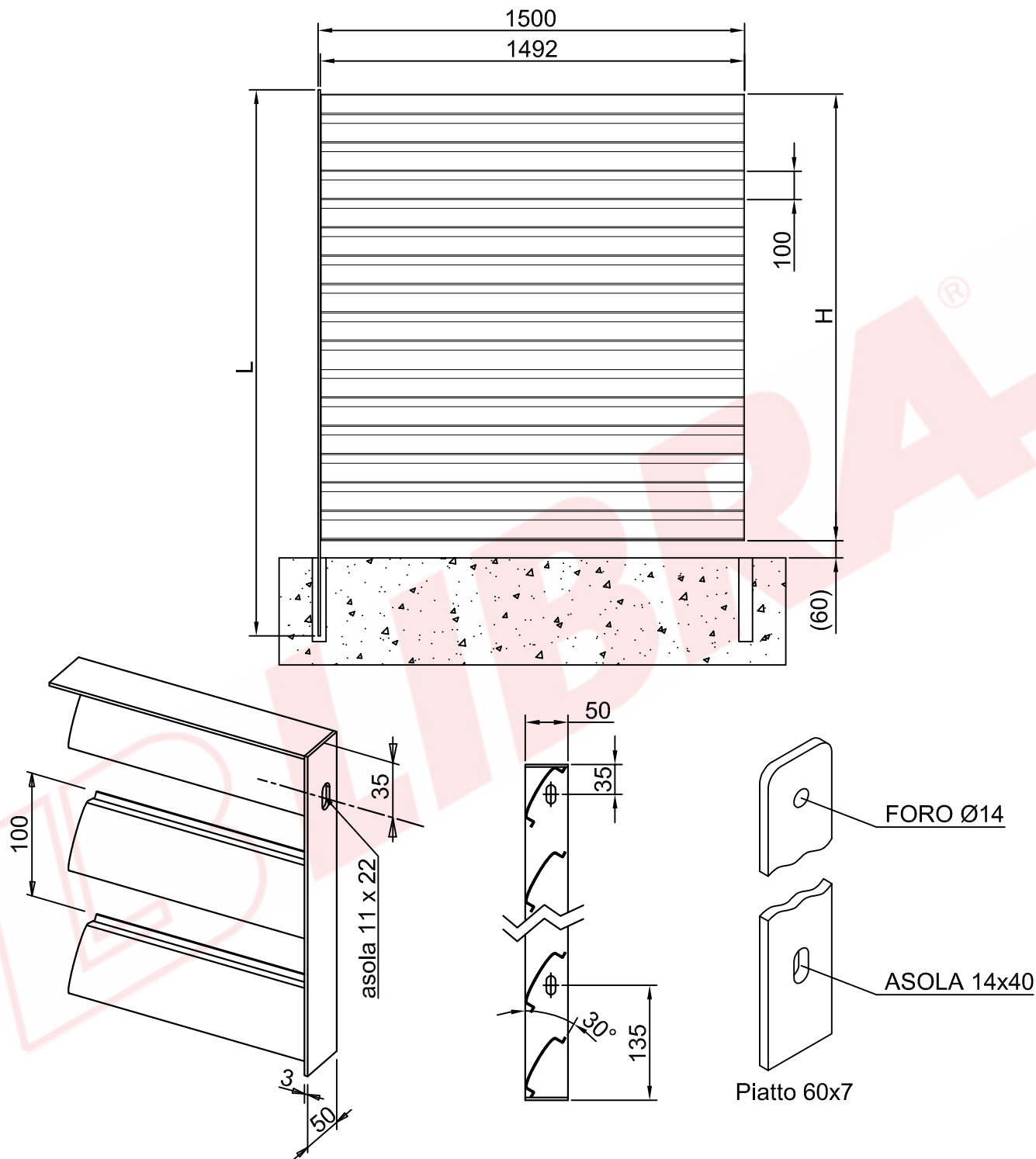

Altezza pannello mm	Peso pannello kg/cad	Tipo piantana mm	Altezza piantana mm	Peso piantana kg/cad
874	22,0	≠ 60x7	1200	4,2
1173	28,2	≠ 60x7	1500	5,2
1372	32,4	≠ 60x7	1750	6,1
1572	36,5	≠ 60x7	1950	6,8

Materiale: S235JR EN 10025

Trattamento superficiale: Zincatura a caldo UNI EN ISO 1461

Piantana in piatto con piastra di base

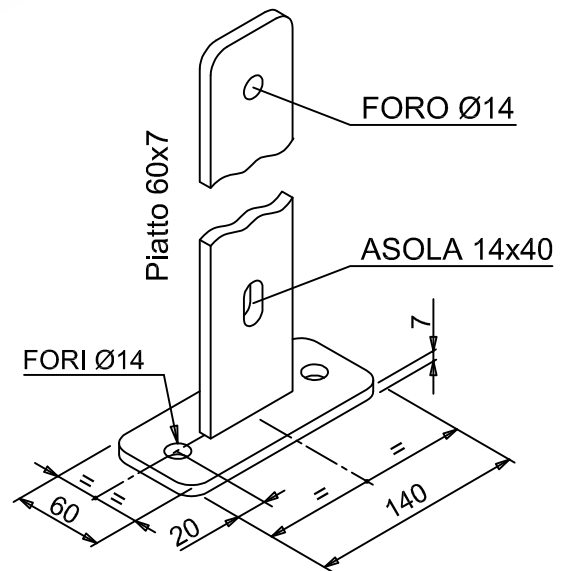
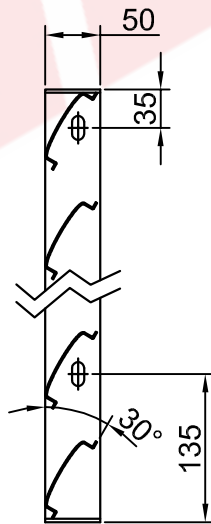
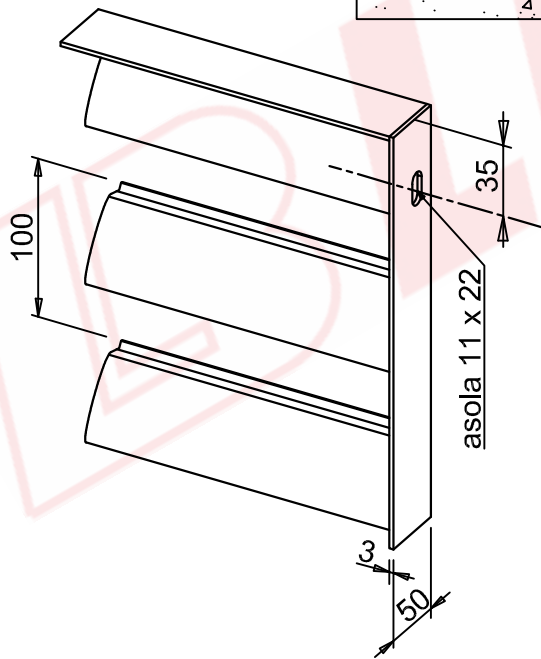
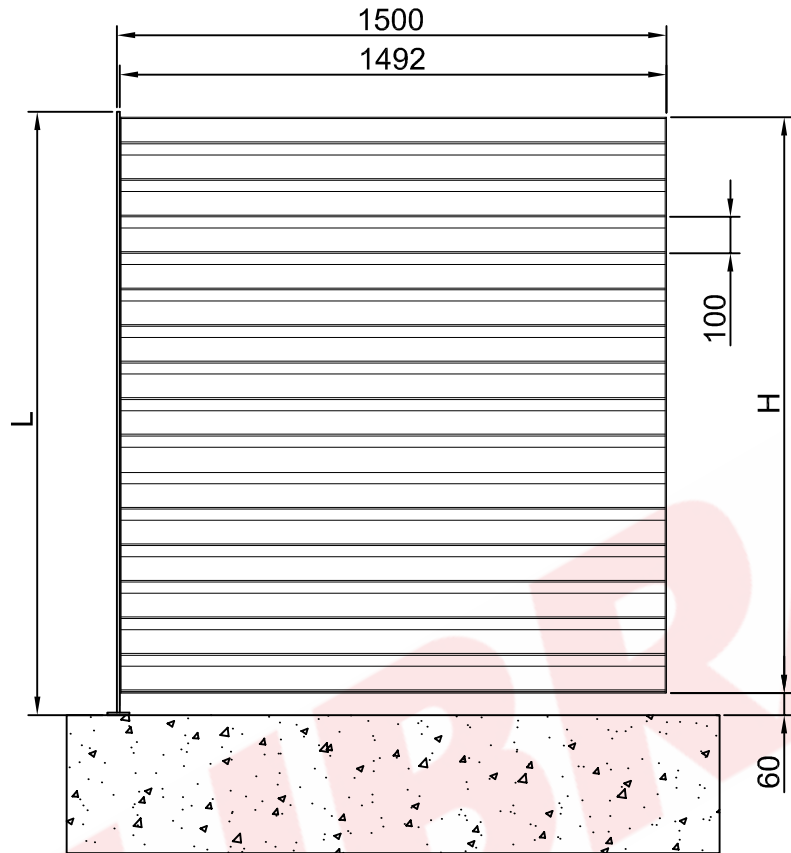

Altezza pannello mm	Peso pannello kg/cad	Tipo piantana mm	Altezza piantana mm	Peso piantana kg/cad
874	22,0	≠ 60x7	949	3,8
1173	28,2	≠ 60x7	1248	4,9
1372	32,4	≠ 60x7	1448	5,5
1572	36,5	≠ 60x7	1647	6,2

Materiale: S235JR EN 10025

Trattamento superficiale: Zincatura a caldo UNI EN ISO 1461