

Piantana in piatto ad annegare

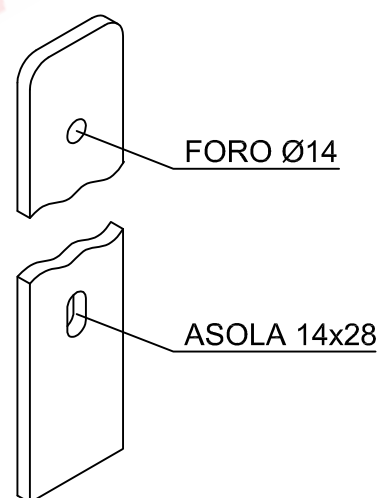
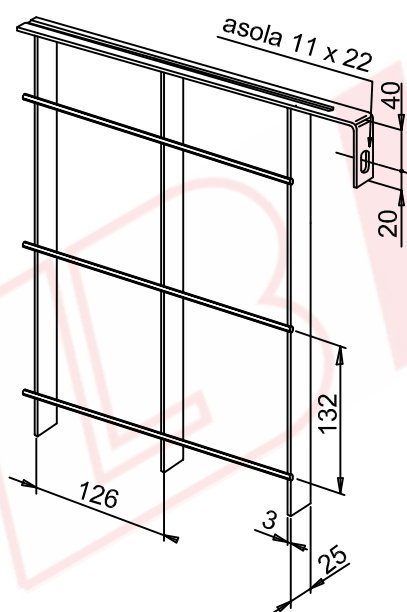
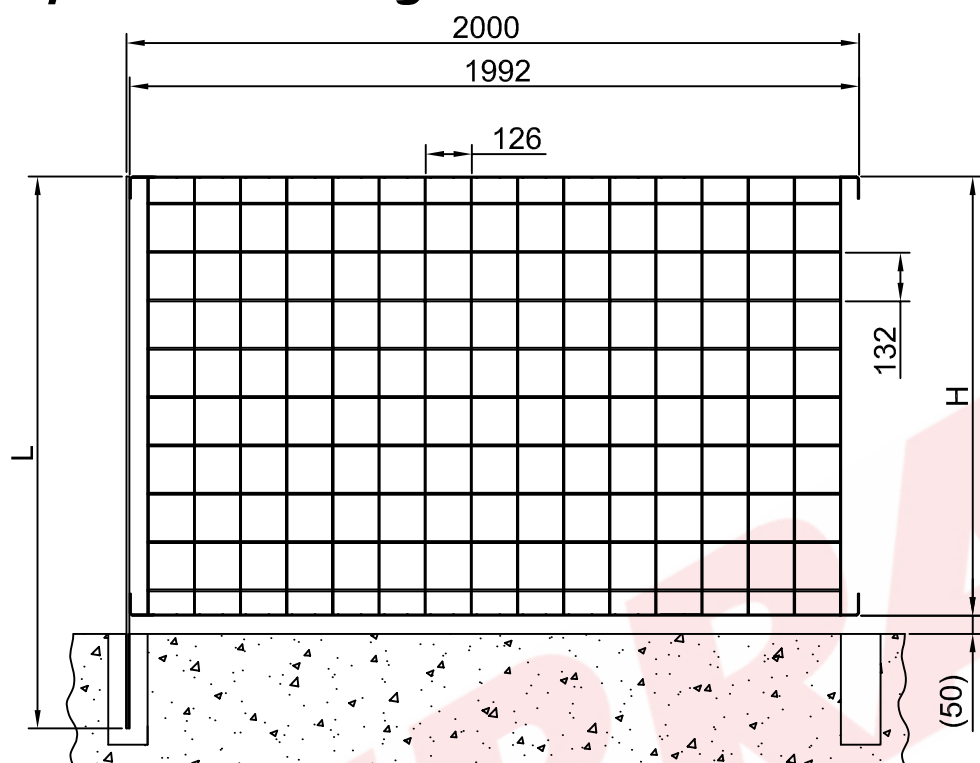

Altezza pannello mm	Peso pannello kg/cad	Tipo piantana mm	Altezza piantana mm	Peso piantana kg/cad
930	12,8	≠ 60x7	1200	4,2
1195	15,7	≠ 60x7	1465	5,1
1320	17,0	≠ 60x7	1650	5,8
1460	18,5	≠ 60x7	1790	6,3
1720	21,3	≠ 60x7	2085	7,3
1985	24,1	≠ 60x7	2350	8,2

Materiale: S235JR EN 10025

Trattamento superficiale: Zincatura a caldo UNI EN ISO 1461

Piantana in piatto con piastra di base

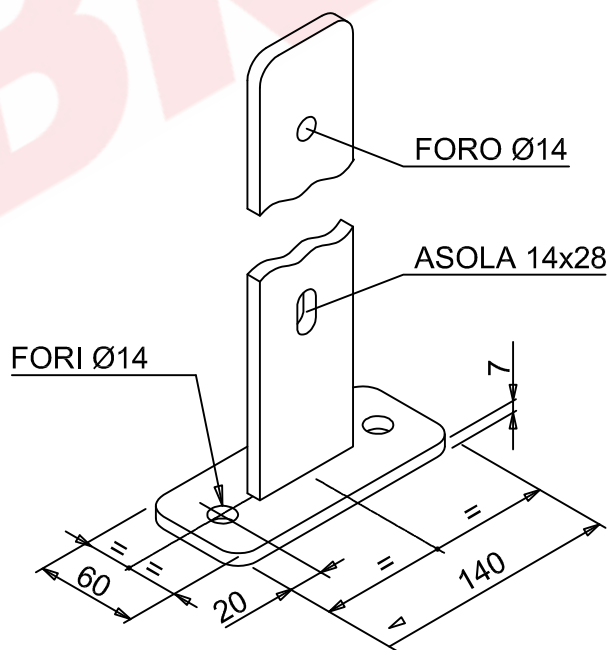
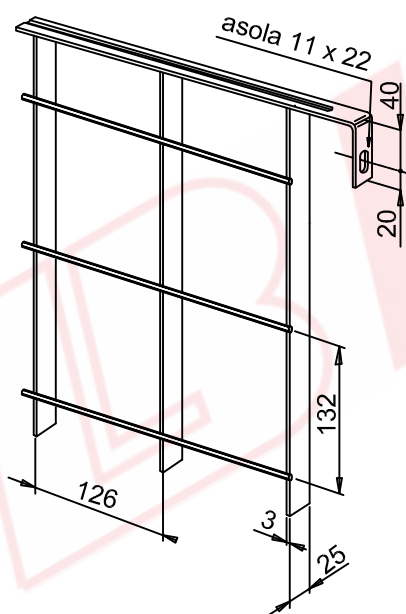
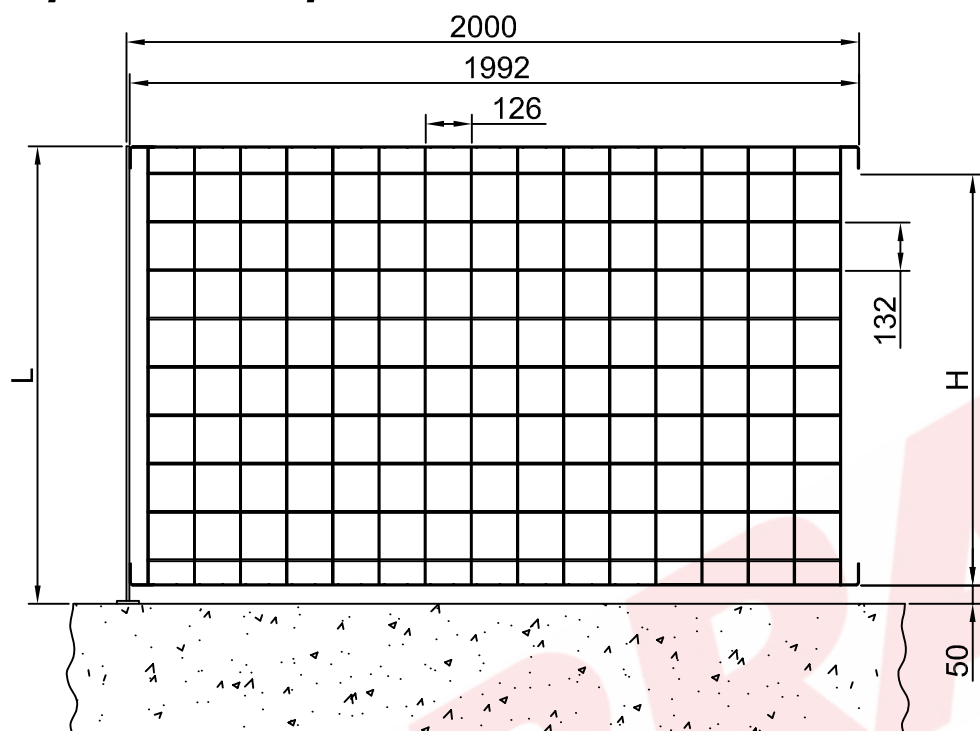

Altezza pannello mm	Peso pannello kg/cad	Tipo piantana mm	Altezza piantana mm	Peso piantana kg/cad
930	12,8	≠ 60x7	990	3,9
1195	15,7	≠ 60x7	1255	4,9
1320	17,0	≠ 60x7	1380	5,3
1460	18,5	≠ 60x7	1520	5,8
1720	21,3	≠ 60x7	1780	6,7
1985	24,1	≠ 60x7	2045	7,6

Materiale: S235JR EN 10025

Trattamento superficiale: Zincatura a caldo UNI EN ISO 1461

Piantana STYLE ad annegare

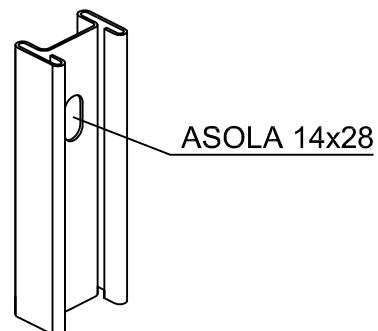
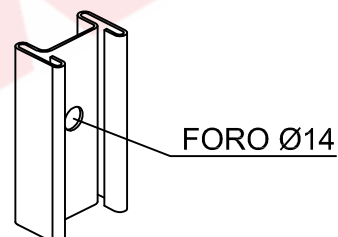
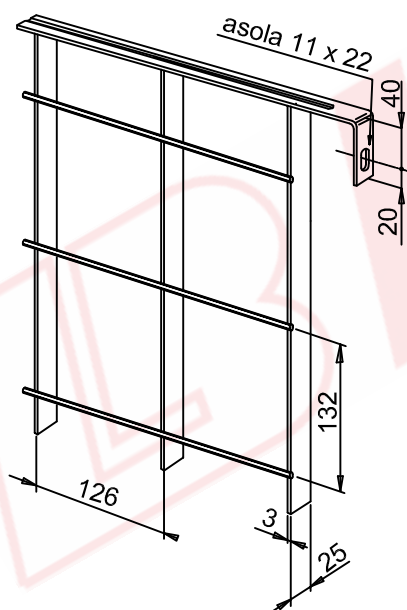
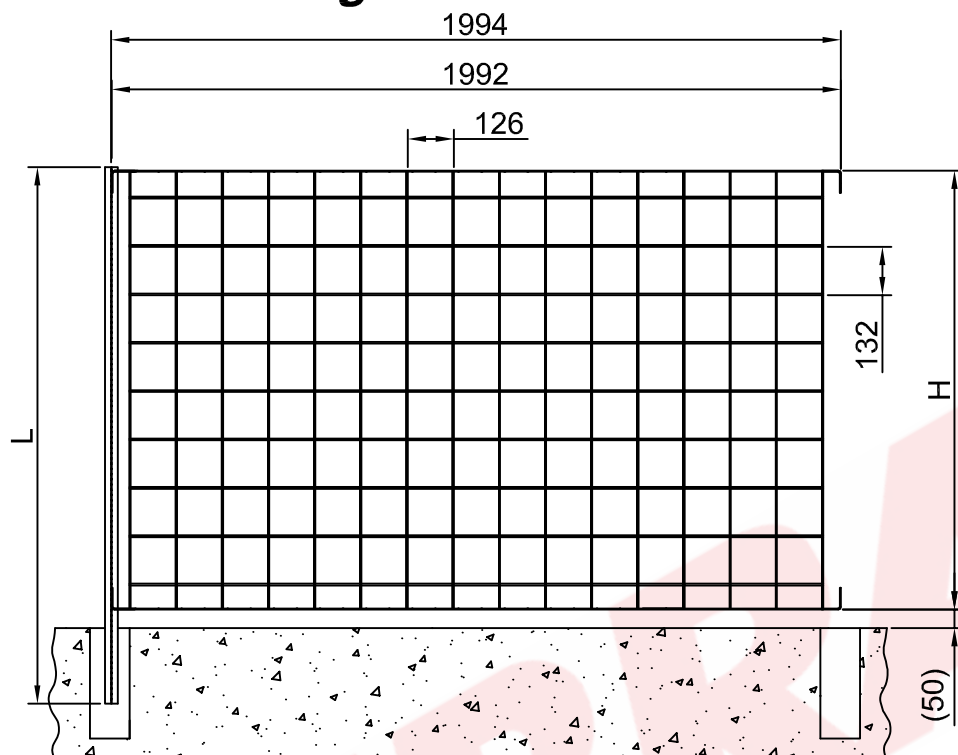

Altezza pannello mm	Peso pannello kg/cad	Tipo piantana	Altezza piantana mm	Peso piantana kg/cad
930	12,8	PROFILATA	1200	3,0
1195	15,7	PROFILATA	1465	3,7
1320	17,0	PROFILATA	1650	4,2
1460	18,5	PROFILATA	1790	4,5
1720	21,3	PROFILATA	2085	5,3
1985	24,1	PROFILATA	2350	6,0

Materiale: S235JR EN 10025

Trattamento superficiale: Zincatura a caldo UNI EN ISO 1461

Piantana STYLE con piastra di base

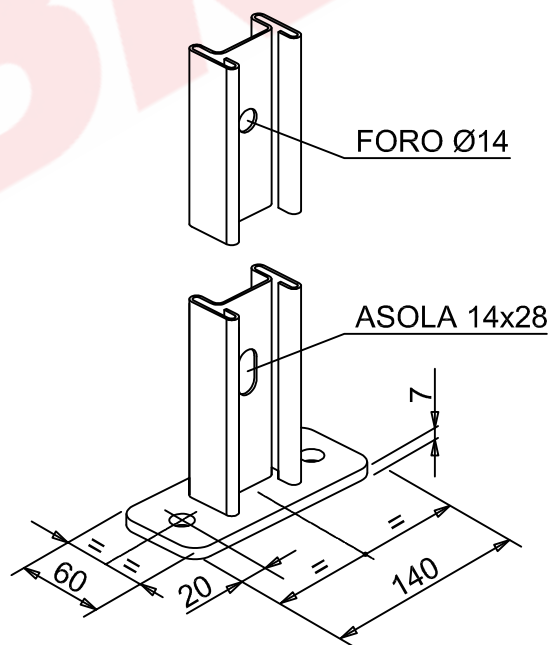
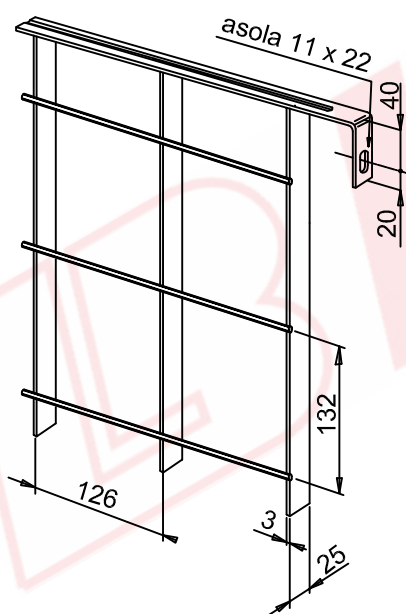
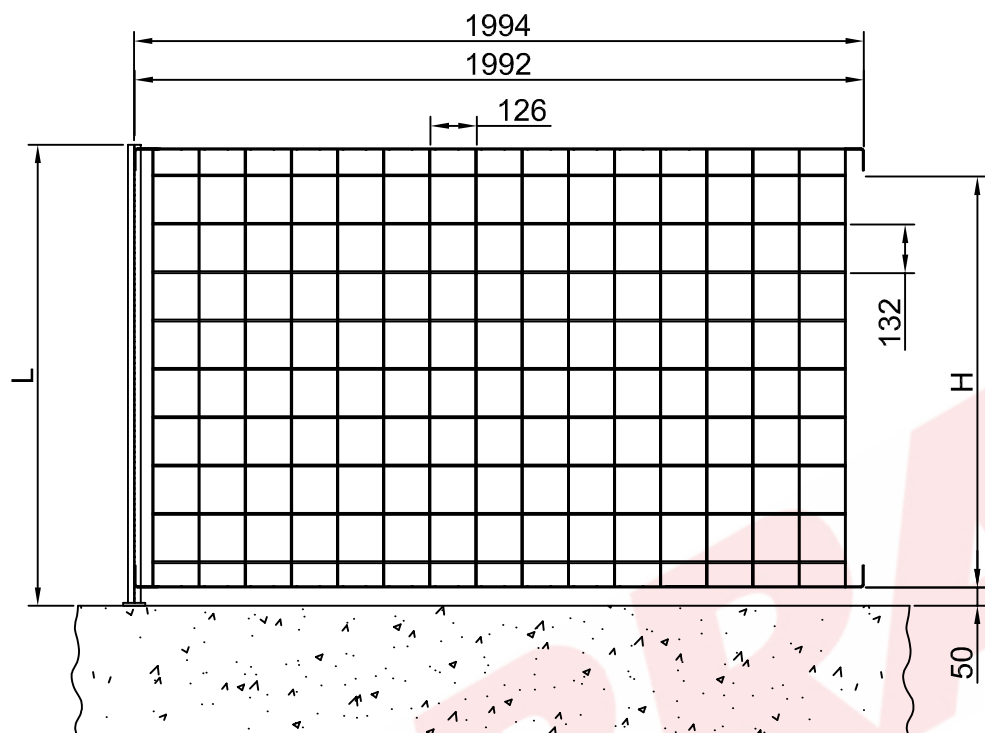

Altezza pannello mm	Peso pannello kg/cad	Tipo piantana	Altezza piantana mm	Peso piantana kg/cad
930	12,8	PROFILATA	990	3,0
1195	15,7	PROFILATA	1255	3,7
1320	17,0	PROFILATA	1380	4,0
1460	18,5	PROFILATA	1520	4,3
1720	21,3	PROFILATA	1780	5,0
1985	24,1	PROFILATA	2045	5,7

Materiale: S235JR EN 10025

Trattamento superficiale: Zincatura a caldo UNI EN ISO 1461